

*your choice*  
**SHIMA SEIKI**



# SSG 234SV / 234SC

Four-System Computerized Flat Knitting Machine with Tandem Capability

## FLEXIBLE SOLUTIONS WITH WIDEGAUGE® AND WideTandem®

The SSG®234SV and SSG®234SC are part of a new generation of computerized knitting machines by SHIMA SEIKI, whose evolutionary progress has resulted in a fine balance of quality, productivity, user-friendliness and economy. In addition to such benchmark technology as the Spring-Type Full Sinker System and DSCS® Digital Stitch Control System, SSG®234SV and SC feature enhanced mechatronics for higher productivity, a built-in controller for space-efficiency, a lower height for ease of use, as well as improved cost-performance and easier maintenance. Such new technology as WideGauge® knitting, the R2CARRIAGE® and WideTandem® capability further add to the SSG®234's appeal.

### WIDEGAUGE® Knitting

Special knitting needles on SSG®234SV offer WideGauge® capability whereby a variety of gauges—from finer-gauges using all-needle knitting, to lower-gauges using half-gauge knitting—can be knit on a single machine. This allows the freedom to handle changing seasons and shifting trends without investing in a machine for every gauge or resorting to the complex, time-consuming task of gauge conversion.

### R2CARRIAGE®

The R2CARRIAGE® (R2=Rapid Response) System increases maximum knitting speed over previous SES® models. More importantly,

the R2CARRIAGE® achieves quicker carriage returns after each course. Combined, these improvements result in significant increases in productivity depending on the gauge and type of fabric.

### WideTandem® Capability for Flexible Operation

SSG®234's twin carriages maximize the 90-inch knitting width through WideTandem® capability. Like the SES®234-S before, SSG®234SV and 234SC can knit panels along the entire width of the needle bed in four-system mode, or two identical pieces in tandem mode. Furthermore with WideTandem®, knitting width in tandem mode stretches from 37 to 42 inches, a significant increase in versatility that matches the capability of the larger SES®254-S.



Knitting Width



KNITRAN System



R2CARRIAGE System



WideTandem



Tough Needle Bed

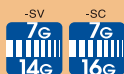

Gauge Range



WideGauge



Gaugeless Knitting



Solenoid Needle Selection



Stitch Presser



Full-Time Sinker



DSCS



Takedown Rollers



Dust Cleaner



Schedule Knit



Back-Lit LCD Panel



Network Interface



Pattern Memory



USB Memory Interface



Back-up Power

## DIMENSIONS

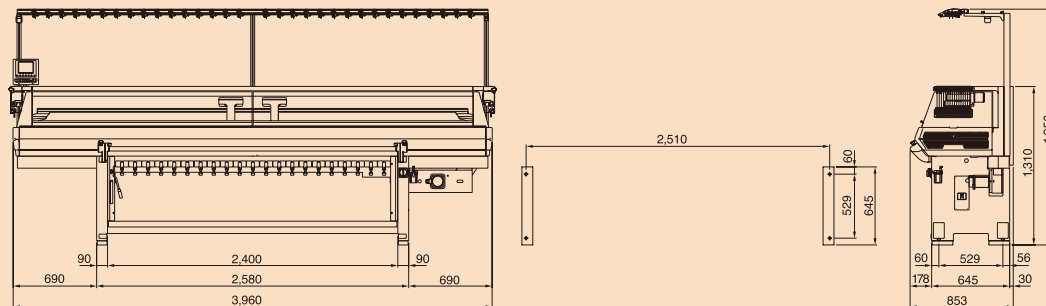

### Average Weight

SSG234 1,375kg (3,025 lbs.)

Actual weight is dependent upon gauge and optional equipment.

All dimensions are in millimeters.

## Fully Fashioned High-Speed Knitting Machine

## SPECIFICATIONS

Type	SSG234SV	SSG234SC
Gauge	7 · 12 · 14	7 · 8 · 10 · 12 · 14 · 16
Knitting width	Variable stroke, max 90" (229cm)	
Tandem width	Max 42" (107cm)x 2, WideTandem®(same knitting width as SES®254)	
WideGauge®	Wide range of gauge knit on a single machine (SV only).	
Knitting speed	Max 1.3m/sec. Knitting speed varies according to yarn, gauge and other knitting conditions. Speed can be programmed for 10 separate categories.	
Stitch density	70 levels, electronically controlled	
Racking	Motor-driven. Max 1 inch racking each side (2 inches total). 1/2 and 1/4 pitch also available from any position.	
Knitting system	Double KNITRAN® system, twin (R2CARRIAGE® system)	
Transfer	Simultaneous transfer, front or back, independent of carriage direction. Split stitch possible without exchanging yarn carriers.	
Sinker system	Spring-type moveable full-sinker system. Provides gentle holddown instead of forcibly pressing down yarn.	
Stitch presser	Special motor-driven system allows individual adjustment for on/off in knit and transfer.	
Needle hook conversion	Conversion between LL-size and MM-size possible without exchanging cams (SV only).	
Needle selection	Full jacquard selection via special solenoid actuators.	
Takedown device	Main rollers: Changeable 99 levels, automatically adjustable on each level. Sub rollers: Changeable 99 levels, automatically adjustable on each level. Automatic opening and closing.	
DSCS® 1	Digital Stitch Control System. Consistent loop length by digital control method. 4 encoders and yarn feed roller with 10 positions on both sides as basic configuration to allow yarn supply from both sides during tandem operation.	
Yarn feed roller 2	10 positions on both sides standard (SV7G only)	
Side tensions	16 on each side	
Yarn carriers	16 normal carriers + 2 plating carriers (accessory)	
Top tension	32 units. One-touch easy threading. Large knots cause machine stop. Small knots cause 0-9 courses at specified knot detection speed, then automatically resume at set speed.	
Stop motion	Yarn break, large knot, fabric pileup, shock detection, piece count, over-torque, program error, etc.	
Drive system	Belt drive. AC servo motor. No lubrication necessary.	
Cleaner	Special blower operated cleaner	
Safety devices	Full safety cover for noise-suppression and dust-proofing with stop motion sensor and interlock mechanism. Emergency stop switch. Emergency power off device. Ultra-low speed "crawl" setting. CE Mark. Operation lamp (see below).	
Operation lamp	Green/normal operation. Flashing green/normal stop. Flashing amber/abnormal stop.	

## CONTROLLER

Data input	USB memory interface. Ethernet 10/100 BASE-T network interface.
Pattern memory	25,165,824 bits (1,024 wales x 8,192 addresses)
Control unit	Built-in controller. Stored program for flat knitting machine.
Control display	Monochrome LCD panel. Editing possible via display panel operation. Available in English, French, Italian, Spanish, Portuguese, German, Turkish, Arabic, Russian, Chinese, Korean and Japanese.
Back-up power	Power supply for resuming knitting after power failure.
Power	3 phase AC200V±10% 3.2kVA

**OPTIONS:** (1) DSCS® (2) Yarn feed rollers (10 positions) on both sides

**ISO14001 Certification** SHIMA SEIKI Headquarters is certified as an ISO14001 accredited company.

*your choice*  
**SHIMA SEIKI**

### SHIMA SEIKI MFG., LTD.

85 Sakata Wakayama, 641-8511 JAPAN  
TEL +81-73-474-8210 FAX +81-73-474-8270

### SHIMA SEIKI EUROPE, LTD.

Sills Road, Willow Farm Business Park,  
Castle Donington, Derbyshire DE74 2US U.K.  
TEL +44-1332-814770 FAX +44-1332-850272

### SHIMA SEIKI ITALIA S.p.A.

Via Redecesio 11-20090 Segrate (MI) ITALY  
TEL +39-02-216621 FAX +39-02-2139410

### SHIMA SEIKI SPAIN, S.A.U.

Poligono Industrial Can Salvatella, Calle Comadran 35  
08210 Barbera Del Valles, Barcelona, SPAIN  
TEL +34-93-7293727 FAX +34-93-7180626

### SHIMA SEIKI FRANCE SARL

24, Rue du Moulin des Bruyeres 92400 Courbevoie, FRANCE  
TEL +33-1-47-88-27-42 FAX +33-1-47-88-10-78

### SHIMA SEIKI U.S.A. INC.

22 Abeel Road, Monroe Twp., New Jersey 08831 U.S.A.  
TEL +1-609-655-4788 FAX +1-609-655-3989

### SHIMA SEIKI (HONG KONG) LTD.

3/F, S.A.C.C., 64 Tsun Yip Street,  
Kwun Tong, Kowloon, HONG KONG  
TEL +852-2898-8339 FAX +852-2558-8332

### SHIMA SEIKI KOREA INC.

Seojung Bldg, 47, Ahasan-Ro 58-Gil,  
Gwangjin-Gu, Seoul, KOREA 143-831  
TEL +82-2-2216-4057 FAX +82-2-2216-4711

### SHIMA SEIKI MFG., LTD., TAIPEI BRANCH

1F, 30, Lane 583, Ruey Kuang Rd., Neihu, Taipei 11492, TAIWAN  
TEL +886-2-8752-3388 FAX +886-2-8797-5522

URL <http://www.shimaseiki.com>

SHIMA SEIKI, SES, SSG, KNITRAN, R2CARRIAGE, WideTandem, WideGauge and DSCS are either registered trademarks or trademarks of SHIMA SEIKI MFG., LTD. in Japan and / or other countries. SHIMA SEIKI maintains a policy of continuous improvement for its products, and therefore specifications and appearances are subject to change without notice. Please contact your nearest authorized sales representative for the latest information.

**SAFETY NOTICE** In order to ensure safe operation of the equipment, please review all operation manuals carefully before use.

SSG234SV/234SC Printed in Japan