

# New SES122/123/183RT



Computerized Flat Knitting Machine with Rib Transfer Capability



**SHIMA SEIKI**

# New SES<sub>122/123/183</sub>RT

## ENHANCED PATTERNING WITH INNOVATIVE TRANSFER CAPABILITY.

The SES122RT revolutionized flatbed knitting with its innovative four-bed design by introducing unprecedented patterning possibilities to the industry. Its capabilities are now extended even further with the NewSES-RT line-up, consisting of the NewSES122RT, NewSES123RT and NewSES183RT. All three feature split transfer jack beds for greater transfer capability and yarn carrier kickback device for enhanced intarsia and integral knitting. A new, variably adjustable Second Stitch cam also provides enhanced shaping. These new functions greatly improve productivity—even more for the NewSES123RT and NewSES183RT, which—feature a triple-cam carriage. Multiple transfer capability with the four-bed system improves shaping and integral knitting through the use of inside narrowing of rib stitches, tubular stitches, Milano rib stitches and cardigan rib stitches, allowing the exploration of new dimensions in knitwear. Tailored jackets, coats, suits, skirts, pants and dresses offer the sophisticated, high-quality look of woven textiles while maintaining the softness and stretchable characteristics that only knitwear can provide.

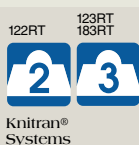
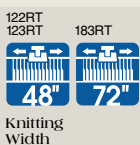

## The unique transfer capabilities of a four-bed system

The innovative four-needlebed configuration of the NewSES-RT combines two additional beds to the conventional V-bed design. This arrangement combines conventional transfer between the lower front and rear beds along with transfer with each of the additional upper beds, resulting in a unique setup which allows tremendous capabilities never before possible in flatbed knitting. Moreover, productivity is not hampered in the slightest degree since these combined transfers

can be made without even stopping the carriage. New to the NewSES-RT type machines are transfer jack beds which can be split for individual left-right racking control.

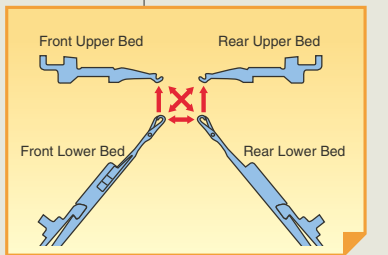

Transfer capability among the 4 beds of the NewSES-RT

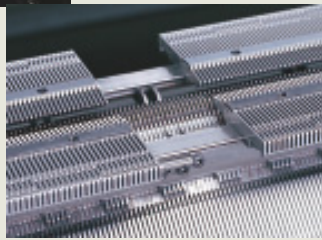

## The world's first digital stitch device

Considered one of the most significant breakthroughs in flatbed knitting technology, the patented Digital Stitch Control System (DSCS®), the first of its kind, treats each stitch as digital data. Once a specific loop length is programmed, it continuously adjusts yarn feed and tension to yield consistency in every loop of each course, with tolerance to within a remarkable  $\pm 1\%$ . The result is quality control capability that is virtually impossible with conventional analog systems.

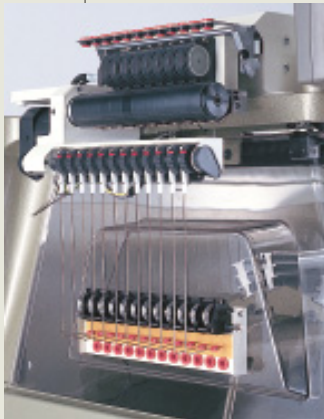

Once a specific loop length is programmed, it continuously adjusts yarn feed and tension to yield consistency in every loop of each course, with tolerance to within a remarkable  $\pm 1\%$ . The result is quality control capability that is virtually impossible with conventional analog systems.

DSCS® is a crucial factor in full-fashioning and integral garment production, as well as for maintaining consistency among different batches and repeat orders.

## Second Stitch Control

A special Second Stitch cam allows loose/tight stitches for shaping. The motor-controlled cam allows variable adjustment of loose to tight stitches, controllable for each individual needle. Instantaneous changes for individual needles is possible, greatly enhancing the NewSES-RT's shaping capabilities.

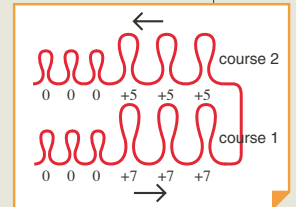

## Yarn carrier kickback device

When knitting integral garments and intarsia on conventional V-bed systems, the yarn carrier is positioned by carriage movement. After knitting the integral or intarsia portion for each course, the carriage must spend a dedicated course specifically for moving the yarn carrier out of the way in order to knit the next course, resulting in wasted "empty courses." In sharp contrast, the NewSES-RT's yarn carrier kickback device features a motor-driven active carrier system whereby the carrier lifts itself up and over to make way for the carriage's next knitting course, eliminating the need for any extra empty courses and significantly improving productivity.



## Back-lit LCD panel

The NewSES-RT features a new back-lit LCD control panel for enhanced viewing and operability. The eye-level display offers improved ergonomics, while menu-interactive function buttons offer easy input and editing. The multi-lingual menu is available in English, Italian, French, German, Spanish, Turkish, Chinese and Japanese.



## DIMENSIONS

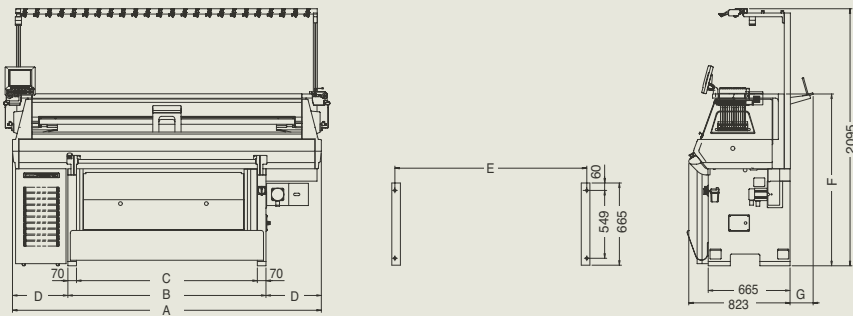

### Average Weight

|             |                   |
|-------------|-------------------|
| NewSES122RT | 1,096 (2,411 lbs) |
| NewSES123RT | 1,165 (2,563 lbs) |
| NewSES183RT | 1,388 (3,054 lbs) |

Actual weight is dependent upon gauge and optional equipment.

|             | A     | B     | C     | D   | E     | F     | G   |
|-------------|-------|-------|-------|-----|-------|-------|-----|
| NewSES122RT | 2,510 | 1,610 | 1,470 | 480 | 1,560 | 1,390 | 188 |
| NewSES123RT | 2,920 | 1,610 | 1,470 | 655 | 1,560 | 1,405 | —   |
| NewSES183RT | 3,272 | 2,210 | 2,070 | 531 | 2,160 | 1,405 | —   |

All dimensions are in millimeters.

## SPECIFICATIONS

| Type                        | N.SES122RT   | N.SES123RT   | N.SES183RT                   |
|-----------------------------|--|--|------------------------------|
| Gauge                       | 12, 14   |  |                              |
| Knitting width (max)        | Variable stroke. 48" (122cm)   |  | Variable stroke. 72" (183cm) |
| Knitting speed              | Max 1.2m/sec. Knitting speed varies according to gauge and knitting condition. Variably adjustable speed levels.<br>16 additional programmable speeds.   |  |                              |
| Stitch density              | 70 levels, electronically controlled.  |  |                              |
| Second stitch               | Fixed second stitch cam  | Motor-controlled second stitch cam allows individual adjustment of loose/tight stitches for shaping. |                              |
| Racking                     | Motor-driven. Max 1.5-inch racking in each direction (3 inches total). Transfer jack bed is split for individual racking control.<br>Racking of front and back transfer jack beds are performed as one.  |  |                              |
| Knitting system             | Double KNITRAN® system. Single carriage.   | Triple KNITRAN® system. Single carriage.   |                              |
| Transfer                    | Lower bed: Simultaneous transfer, front and back, independent of carriage direction. Split stitch<br>Upper bed: Lower needle bed to either upper transfer jack bed through trailing system. Upper transfer jack bed to opposite lower needle bed through leading system. |  |                              |
| Stitch presser              | Special motor-driven system allows individual adjustment for on/off in knit and transfer.  |  |                              |
| Needle selection            | Full jacquard selection via special solenoid actuators.  |  |                              |
| Setup device                | Takedown comb with special setup needles.  |  |                              |
| Takedown device             | Main/sub rollers. Changeable 99 levels, automatically adjustable on each level. Automatic opening and closing.   |  |                              |
| Yarn cutter                 | Single-unit system includes 1 yarn cutter and 2 yarn grippers. Left side only. <sup>1</sup>  |  |                              |
| DSCS®                       | Consistent loop length by digital control method. Left side standard. Left side yarn feed roller standard. <sup>2</sup> Yarn feed: 8 positions.  |  |                              |
| Side tension                | 8 on each side <sup>3</sup>  | 12 on each side  |                              |
| Yarn carriers               | 9 carriers   | 12 carriers  |                              |
| Yarn carrier kickback       | Kickback device using servo belt drive. Eliminates the need for empty courses. 2 tracks on each side (4 tracks total) as standard configuration. <sup>4</sup>  |  |                              |
| Top tensions                | 16 tension devices <sup>3</sup>  | 24 tension devices   |                              |
|                             | One-touch easy threading. Large knots cause machine stop. Small knots cause 0-9 courses at specified knot detection speed, then automatically resume at set speed.   |  |                              |
| Stop motion                 | Yarn break, large knot, wraparound check, shock detection, piece count, over-torque, program error, etc.   |  |                              |
| Drive system                | Belt drive. AC servo motor. No lubrication necessary.  |  |                              |
| Cleaner                     | Special blower operated cleaner.   |  |                              |
| Safety devices <sup>5</sup> | Full safety cover for noise-suppression and dust-proofing with stop motion sensor and interlock mechanism. Stop button. Power supply disconnecting device.<br>Ultra-low speed "crawl" setting. Indicator lamps (see below).  |  |                              |
| Operation lamp              | Green/normal operation. Flashing green/normal stop. Flashing amber/abnormal stop.  |  |                              |

## CONTROLLER

|                         |   |  |        |
|-------------------------|---|--|--------|
| Data input <sup>6</sup> | 3.5" floppy disk  |  |        |
| Pattern memory          | 25,165,824 bits (1,024 wales x 8,192 addresses)   |  |        |
| Control system          | Stored program for flat knitting machine.   |  |        |
| Control display         | Back-lit monochrome LCD panel. Editing possible via display panel operation. Available in English, French, Italian, Spanish, German, Turkish, Chinese and Japanese. |  |        |
| Power                   | 3 phase AC200V±10%  |  |        |
|                         | 2.0KVA  |  | 2.2KVA |

**OPTION:** (1) Right side yarn cutter. (2) Right side yarn feed roller. (3) Additional tension devices (for a total of 24 top tensions and 12 side tensions on each side). NewSES122RT only.  
(4) Additional yarn carrier kickback device (2 additional tracks on each side for 8 tracks total). (5) CE Mark. (6) Network interface.



## SAFETY NOTICE

In order to ensure safe operation of the equipment, please read all operation manuals carefully before use.

Shimatronic, Knitran and DSCS are registered trademarks of Shima Seiki Mfg., Ltd.  
Shima Seiki maintains a policy of continuous improvement for its products, and therefore specifications and appearances are subject to change without notice.  
Please contact your nearest authorized sales representative for the latest information.



# SHIMA SEIKI

**SHIMA SEIKI MFG., LTD.**  
85 Sakata Wakayama Japan  
TEL+81-73-474-8210 FAX+81-73-474-8270

**SHIMA SEIKI EUROPE, LTD.**  
Sills Road, Willow Farm Business Park,  
Castle Donnington, Derbyshire DE74 2US U.K.  
TEL 01332-814770 FAX 01332-850272

**SHIMA SEIKI U.S.A., INC.**  
22 Abeel Road Monroe Twp., New Jersey 08831, U.S.A.  
TEL 609-655-4788 FAX 609-655-8463

**SHIMA SEIKI MFG., LTD., TAIPEI BRANCH**  
1F, 30, Lane 583, Ruey Kuang Rd., Neihu, Taipei 114, TAIWAN R.O.C.  
TEL 886-2-8752-3388 FAX 886-2-8797-5522

URL <http://www.shimaseiki.co.jp> Email [info@shimaseiki.co.jp](mailto:info@shimaseiki.co.jp)